

MTL4649/Y ISOLATING DRIVER

two-channel, for 4–20mA, HART®
valve positioners with line fault detection

The MTL4649 accepts 4/20mA floating signals from a controller to drive 2 current/pressure converters (or any other load up to 800Ω). For HART valve positioners, the module also permits bi-directional transmission of digital communication signals. Process controllers with a readback facility can detect open or short circuits in the field wiring: if these occur, the current taken into the terminals drops to a preset level. The MTL4649Y is very similar except that it provides open circuit detection only (i.e. no short-circuit detection).

SPECIFICATION

See also common specification

Number of channels

Two

Working range

4 to 20mA

Digital signal bandwidth

500Hz to 10kHz

Maximum load resistance

800Ω (16V at 20mA)

Minimum load resistance

90Ω (short-circuit detection at < 50Ω)

Output resistance

> 1MΩ

Under/over range capability

Under range = 1mA

Over range = 24mA (load ≤ 520Ω)

Input and output circuit ripple

<40μA peak-to-peak

Communications supported

HART

Transfer accuracy at 20°C

Better than 20μA

Temperature drift

< 1.0μA/°C

Input characteristics

| Field wiring state | MTL4649 | MTL4649Y |
|--------------------|---------|----------|
| Normal | < 6.0V | < 6.0V |
| Open-circuit | < 0.9mA | < 0.5mA |
| Short-circuit | < 0.9mA | N.A. |

MTL4649 / MTL4649Y

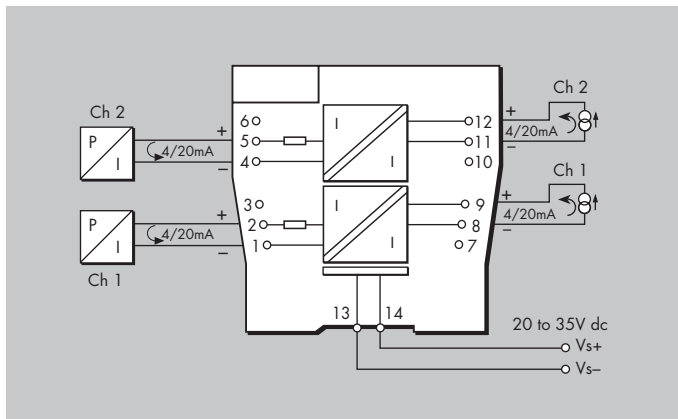

Response time

Settles within 200μA of final value within 100ms

LED indicator

Green: power indication

Maximum current consumption (with 20mA signals into 250Ω load)

70mA at 24V dc

Power dissipation within unit (with 20mA signals into 250Ω load)

1.6W at 24V



Powering Business Worldwide

Eaton Electric Limited,

Great Marlings, Butterfield, Luton
Beds, LU2 8DL, UK.
Tel: + 44 (0)1582 723633 Fax: + 44 (0)1582 422283
E-mail: mtlenquiry@eaton.com
www.mtl-inst.com

© 2016 Eaton
All Rights Reserved
Publication No.
EPS4649/Y Rev 3 010916

EUROPE (EMEA):

+44 (0)1582 723633 mtlenquiry@eaton.com

THE AMERICAS:

+1 800 835 7075 mtl-us-info@eaton.com

ASIA-PACIFIC:

+65 6 645 9888 sales.mtlsing@eaton.com

The given data is only intended as a product description and should not be regarded as a legal warranty of properties or guarantee.

In the interest of further technical developments, we reserve the right to make design changes.